

SAND SILO

Product Catalog

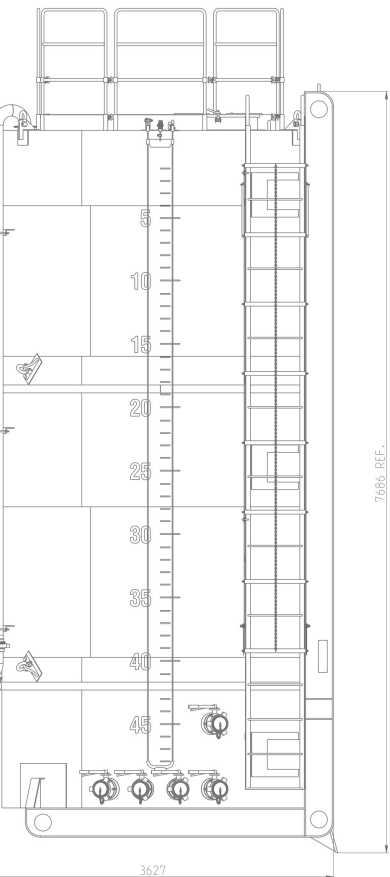
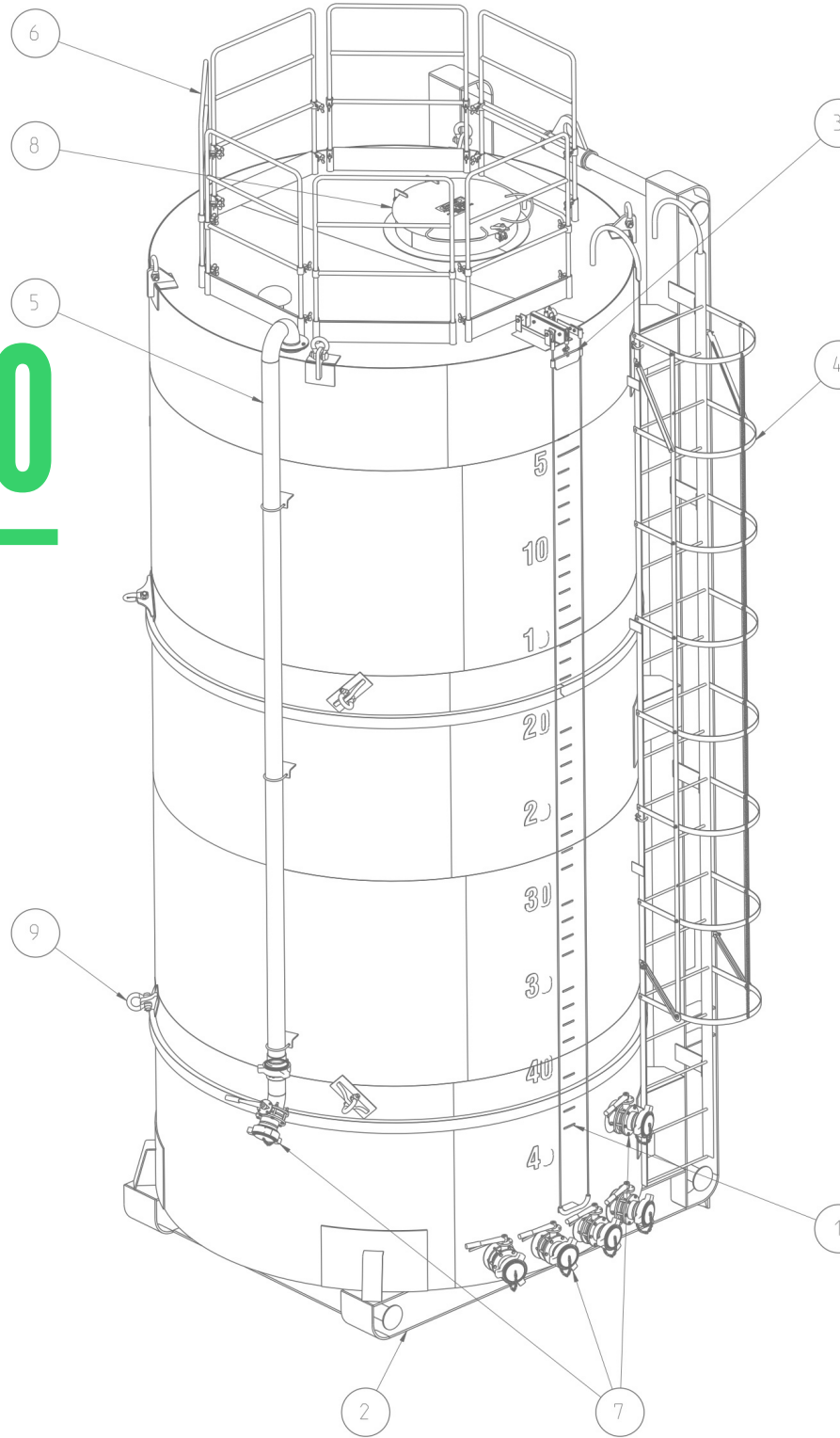

SAND SILO

Sandcastle Proppant Silo

VD Technology center's proppant Silo is a Gravity Discharge Silo, used for temporarily store and deliver proppant during pumping operations.

VD Teachnology Center provides various types of model in proppant silo with different Capacity and Engineering.

TECHNICAL FEATURES

- **Type:** Gravity Discharge Silo.
- **Capacity:** 50MT or 1250 cum / 100MT or 2500 cum.
- **Jumbo Bag entry:** From top Manhole. (1mtr X 1 mtr)
- **Lifting lugs:** Specially designed for trailer loading.
- **Material count:** Specially erected Load cells with Digital display.
- **Painting:** Special 3 coat painting systems used along with sand blasting.
- **End Connection:** Standard Hammer union connection for all ends



SPECIAL FEATURES

- Very less requirement of Manpower.
- Digital enables operator to see operations easy way.
- Great 3 coat painting system make easy to keep silo clean with simple cleaning.
- Easy product for transportation.

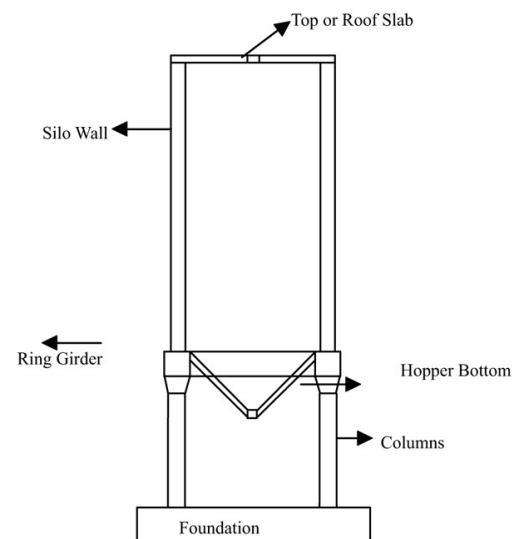

SPECIAL FEATURES

Sliding Discharge Gate:

- Provides smooth operation compare to standard gates.
- Easy flow of fry materials.
- Great pressure holding capacity due to large surface area.
- High leve od sealing in times of shut off.

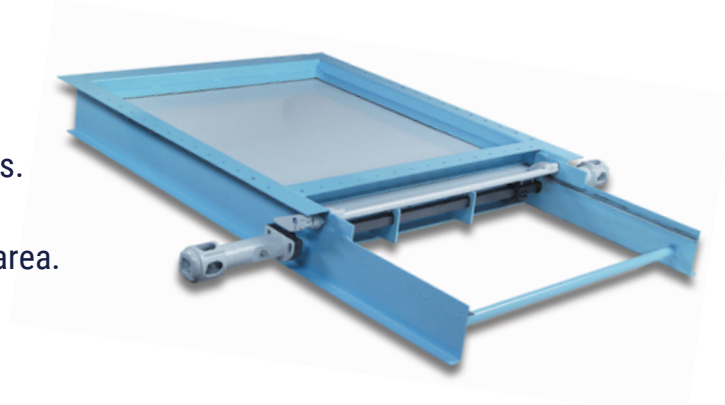

Easy Operation design:

- VDTC designed this discharge silo from better transportation point of view.
- VDTC modify its structure design for silo based on traffic rules of respective country where it gets supplied.
- Load balancing of silo is specially designed for both offshore & onshore liftings.
- Fall arrestors for safe access to the top of the silo.
- Provide temporary storage for proppant during operations.
- Delivery of proppant to blender is smooth and continues.



Equipment Specifications

MODEL	LENGTH	WIDTH	HEIGHT	LIFTING CERTIFICATE	COLOUR SYSTEM
VDTC-GSL-50	487.68 (mm)	2164.08 (mm)	2164.08 (mm)	DNV 2.7.1	3 Coat System
VDTC-GSL-100	10210.8 (mm)	3657.6 (mm)	36.576 (mm)	DNV 2.7.1	3 Coat System

Tailor made proppant silo will be available on the request



An ISO 9001: 2015 Certified Company.

OFFICE:

OFFICE 602, SIXTH FLOOR, MIRAGE
ARCADE CHS LTD, NEHRU ROAD,
OPP. GANESH MANDIR ROAD,
DOMBIVLI EAST, 421201

PLANT:

PLOT F-50 ANAND NAGAR
ADDITIONAL MIDC, BEHIND ASB
INTERNATIONAL PVT. LTD
FACTORY AMBERNATH, 421506

CONTACT

VAIBHAV C. DATE
+91 8097902746

CONTACT

SWAPNIL BHARAMBE
+91 9222853155

WEB

WWW.VDTECHNOLOGYCENTER.COM